

INSTALLATION, OPERATION & MAINTENANCE MANUAL

PLASMA AIR MODELS 7100, 7200, 7300 AND 7400

REV 06/2015

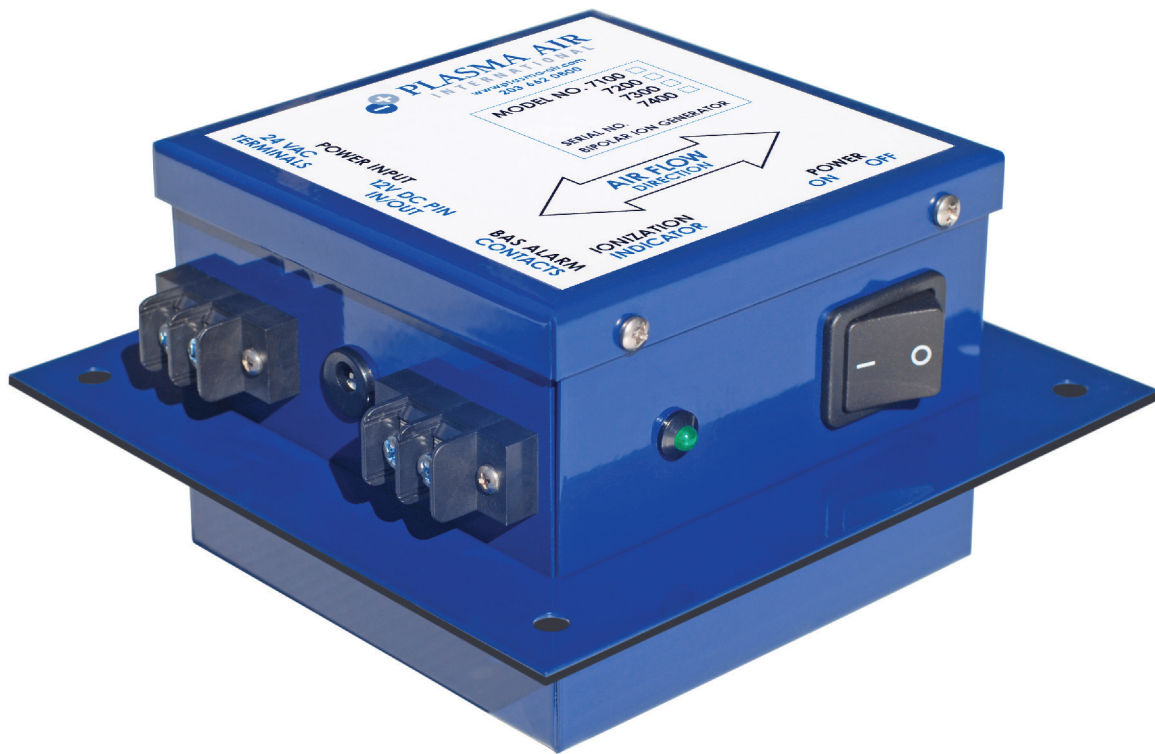

INTRODUCTION

Plasma Air models 7100, 7200, 7300 and 7400 needlepoint air ion generators are single outlet (7100), double outlet (7200), triple outlet (7300) and quad outlet (7400) commercial quality units intended for installation in air handling units (AHU), furnaces, or duct systems for commercial and residential applications.

This ionization equipment is effective in reducing harmful pollutants and odors by introducing positive and negative ions into the system airflow. The number of units and the quantity of the ionization outlets are dependent on the airflow in the system and the severity of the indoor air pollution problem.

MECHANICAL INSTALLATION INSTRUCTIONS

GENERAL MOUNTING CRITERIA:

Caution: To reduce the risk of fire, this unit should not be installed downstream of a humidifier or exposed to other sources of moisture.

Caution: This product is suitable for mounting into duct of metallic construction only. Installation must be such that the structural integrity of the ducting is not compromised.

Mount units to allow access to the ionization unit power switch and connections and for general maintenance. This product shall not be installed behind a suspended floor/ceiling or a structural wall, ceiling, or floor.

1) The preferred location is in the supply air duct as close to the treated space as possible. Be sure to pick a location before any branch duct take-offs. Install in a straight section of duct work a minimum of 3 feet from any duct transitions.

2) To mount the model 7100, 7200, 7300 or 7400 in a duct: (See figure 1)

a) Trace a 4 5/8" x 4 5/8" square (for the 7100 and 7200) or a 4 5/8" wide x 8 3/4" high rectangle (for the 7300 and 7400) on the surface of the duct onto which you are mounting the ionization unit.

b) Cut out the traced portion of the duct using snips or sheet metal shears.

c) Insert the ionization unit into the duct opening so that the flange's gasket is in contact with the outside of the duct. Be sure that the direction of airflow in the duct is parallel with the arrow on the face plate label. Screw the ionization unit onto the duct using sheet metal screws. The units have predrilled mounting holes in the flange to aid in installation.

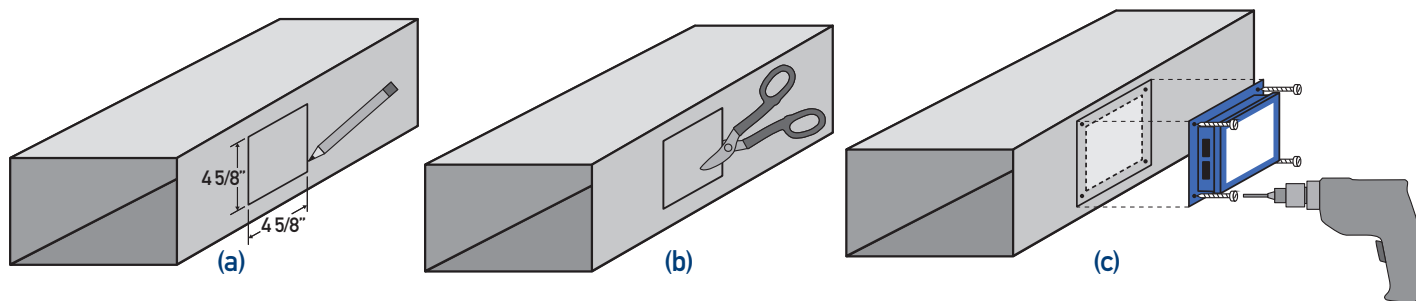

FIGURE 1 – Mounting on duct

3) Connect the power to the unit in the correct location and turn the switch to the “on” position. (see [Electrical Installation on the following page](#))

Mounting location notes:

- Ensure sufficient airflow over the needlepoint electrode outlets.
- Do not mount the units before the system filter.
- Avoid locations where moisture may be present like immediately downstream of a cooling coil.

ELECTRICAL INSTALLATION INSTRUCTIONS

Warning: Do not connect to power before the installation is complete. Always disconnect power to the unit before handling any of the unit components.

1) Models 7100, 7200, 7300 and 7400 are compatible with a variety of primary voltage options. All models accept 24V AC and 12V DC.

- 24V AC power may be connected directly to the terminal block on the outside of the unit. The hot and neutral wires can be connected to either screw terminal. (See figure 2)
- 120V AC or 230V AC will require a factory supplied external power supply to convert the primary power to 12V DC. The 12V DC power is connected to the ionizer via the 2.1 mm pin jack on the unit.

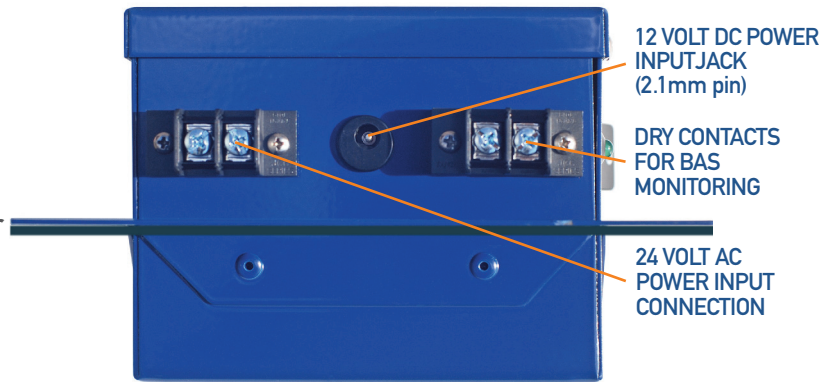

FIGURE 2 – Left view of ionizer

2) The models 7100, 7200, 7300 and 7400 draw less than 1 watt, 2 watts, 3 watts and 4 watts respectively. The power source should not be protected by a circuit breaker exceeding 20 amps.

3) Power may be connected to the ionization unit using any of the following methods:

- Connect 24V AC directly to the power input connection on the ionization unit where indicated.
- Use a factory supplied 120V/230V AC to 12V DC power supply. A 12V DC 2.1mm pin connector shall be inserted into the 12V DC jack provided on the ionization unit. Do not use an extension cord.
- Use a factory supplied 120V AC to 12V DC 500mA wall pack. A 12V DC 2.1mm pin connector shall be inserted into the 12V DC jack provided on the ionization unit. Do not use an extension cord.

4) FIELD WIRING OPTIONS:

• OPTION 1

24V AC FROM CONTROL CIRCUIT

• OPTION 2

120V/230V AC FIELD WIRED THROUGH A FACTORY PROVIDED POWER SUPPLY INSTALLED IN JUNCTION BOX.

• OPTION 3

120V TO 12V DC WALL PACK

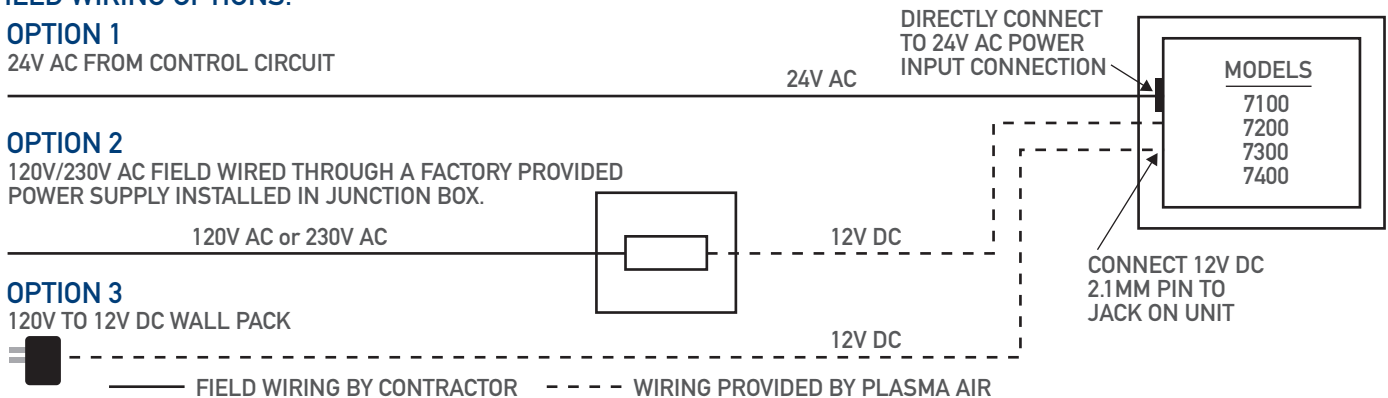

5) INSTALLING MULTIPLE UNITS:

ON SYSTEMS WHERE THE AIRFLOW IS OVER 6,000 CFM, MULTIPLE MODEL 7300s or 7400s WILL BE REQUIRED. WIRE THEM IN SERIES AS SHOWN BELOW:

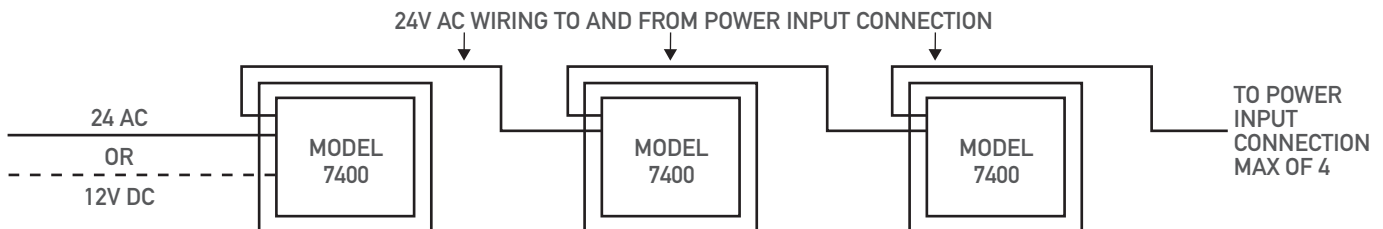

OPERATION

- 1) When power is supplied to the ionizer and the switch is in the “on” position, the ionizer will be activated and will illuminate the green ion indicator light. (See figure 3)
- 2) The ionization unit is self balancing and does not require any type of adjustment.
- 3) The benefit of the ionization unit is realized only when the supply fan is running. Therefore, to achieve improved air quality, interlock the ionizer to run when the supply fan is powered.

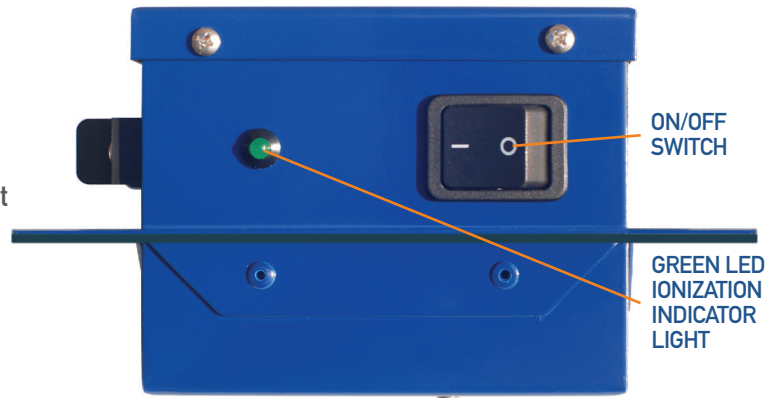

FIGURE 3 – Right view of ionizer

MONITORING CIRCUIT

The model 7100, 7200, 7300 and 7400 ionizers include a monitoring circuit to verify operation status. The circuit consists of a relay with isolated normally open contacts. The contacts remain open whenever the ionization unit is not powered or if there is a fault in the equipment. The contacts close whenever the ionizer is energized and producing ions. Connect the monitoring control wires to the Building Automation System (BAS) dry contacts on the unit. (See figure 2)

TROUBLESHOOTING

If the unit is not working, check in the following order that:

- 1) The ionization unit power switch is on, the supply fan is running and that the green light illuminates.
- 2) Check the power input connections to the ionization unit. Verify all connections are correct and tightened. Reconnect any loose wires as necessary.
- 3) If the unit's internal fuse is blown, wait 2 minutes to allow the unit to automatically reset the fuse. Turn on power to the unit. If the fuse blows again, return the unit to the factory for service.

SEQUENCE OF OPERATION

- 1) For units that are interlocked with the supply fan control, the BAS controls the start/stop of the air conditioning unit supply fan.
- 2) After a 1 minute time delay on a call for supply fan operation, the BAS poles the ionization unit.
- 3) Open contacts indicate a fault; closed contacts indicate normal operation.



Intertek